



GOQLED
powered by **SAMSUNG** america



www.GOQLEDAmerica.com

MODEL : GOQ 3WC108
3 White 1.08 Watt



Features

Most Preferred Best seller LED module : CE, UL, RoHS Certified
Power Consumption : 1.08W
LED provided by SAMSUNG
SMD LED mounted : Made in Korea
LED Driver : Constant Voltage Driving System
Max. 50 modules in series
Fabricated with a CAP TYPE Optical Lens
Each unit can be used to cut.
Best Viewing Angle : **150°**

Enhanced Function

Stylish Appearance design : CAP TYPE
Design for Humid & Waterproof : IP68
Easy Installation & Maintenance

Applications

- * Normal size Channel letters
- * Flex light Box illumination
- * Duplex light Box illumination

Dimensions

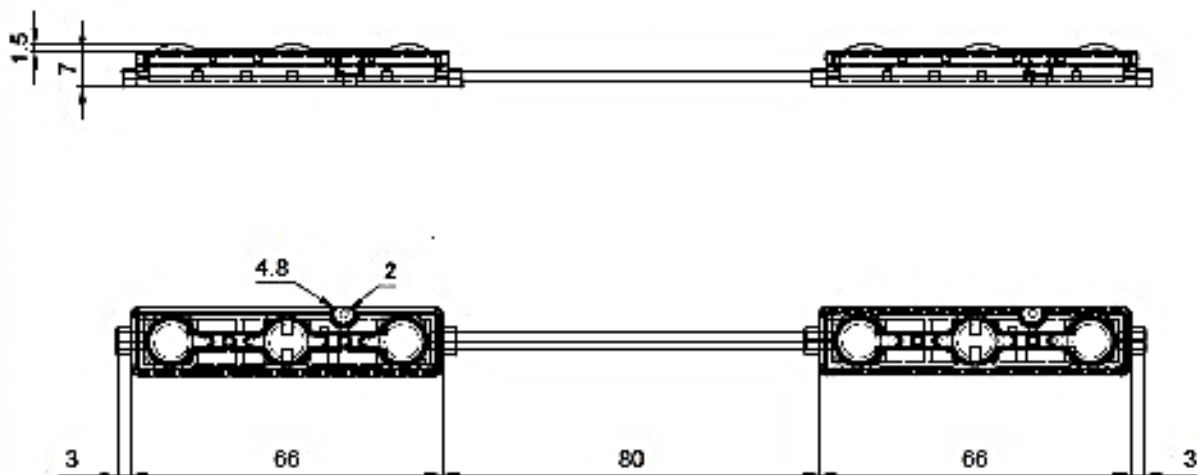

Specifications

Item	Value	Unit
Product No.	GOQ 3WC108	
Power Consumption	1.08	Watt
Input Voltage	12	VDC
Input Current	90	mA
View Angle	150	°
Luminous intensity	90	lm(Typ.)
CRI	80	%
Module Pitch	80	mm
Size	66 X 15 X 8.5	mm
Weight	8	g
Max. in Series	50	EA
Operating Temp	- 30 ~ 85	°C
Storage Temp	- 40 ~ 100	°C
Waterproof	IP68	
Cable	UL, 20AWG 300V/80°C	
Case materials	UL, ABS, V0-class	
Lens materials	UL, SAN, V0-class	

LED Specification



Absolute Maximum Ratings

Item	Symbol	Rating	Condition
Operating temperature range	T_{op}	-40°C ~ +85°C	-
Storage temperature range	T_{stg}	-40°C ~ +120°C	-
LED junction temperature	T_j	110°C	-
Forward Current	I_F	150 mA	-
Peak Pulsed Forward Current	I_{FP}	300 mA	Duty 1/10 pulse width 10ms
Thermal resistance	$R_{th, j-s}$	16°C/W	Junction to solder point
Assembly Process Temperature	-	260°C, < 10sec	-
ESD	-	5kV	HBM

Characteristics

Item	Unit	Nominal CCT	Product Code	Rank	Min	Typ	Max
Forward Voltage ¹⁾ (V_f) (@85 mA, $T_s = 25^\circ\text{C}$)	V	-	-	AZ	2.70	-	2.80
				A1	2.80	-	2.90
				A2	2.90	-	3.00
				A3	3.00	-	3.10
				A4	3.10	-	3.20
Luminous Intensity ²⁾ (I_v) (@85 mA, $T_s = 25^\circ\text{C}$)	lm	10000K	*WAAUS0	S0	24.0	-	31.5
Reverse Voltage (@5 mA, $T_s = 25^\circ\text{C}$)	V	-	-	-	0.7	-	1.2

Spectrum ($T_s=25^\circ\text{C}$)

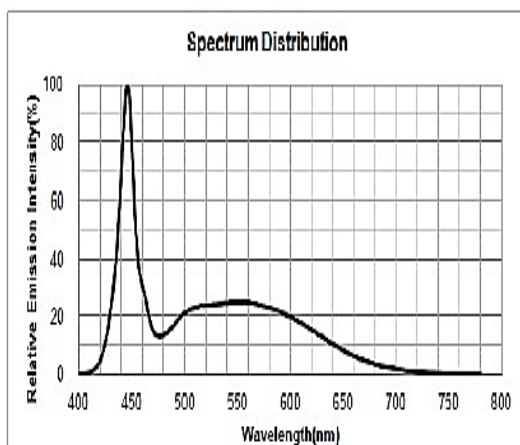

Viewing Radiation Characteristics

